

TRACKSTAR®
QUICKCHANGE
GUIDE RAIL SYSTEMS

TRACKSTAR® QUICKCHANGE GUIDE RAIL SYSTEMS

The TRACKSTAR QUICKCHANGE® Advantage

- 75% typical reduction in changeover time.
- Eliminate the need for dedicated lines.
- No tools required.
- Corrosion-resistant stainless steel and composite construction.
- Improved line productivity.
- Guaranteed set-up repeatability.
- UHMW guides available in tapered and C3 design for complete project.
- Four design options to choose from for optimum performance.
- Available for straight and corner conveyor sections.
- 100% made in the USA.

The high cost of modern high-speed bottling and packaging lines necessitates flexibility to run different sized bottles or packages with minimum downtime. Every minute your line isn't running results in lost profits that can never be recovered.

Fenner Drives' Trackstar QuickChange Systems were designed in cooperation with a major bottler who recognized the need for a new system to quickly and efficiently adjust their guide rails for multiple product sizes.

Now, you too can cut downtime and increase your profitability with Fenner Drives' patented QuickChange System!



TRACKSTAR QUICKCHANGE® Brackets

QCI...

The Original

Construction

The base is molded in high strength glass-reinforced nylon. The center post, sleeve, spring, and shaft are precision machined from stainless steel.

Set-Up

Initial set up is quick and easy. Mount brackets to frame (with MB1005 bracket spacers, if necessary) with no spacers in place. Using the stainless steel adjustment bolt, move the bracket sleeve to accommodate your largest bottle size. When in place, tighten down. Your QuickChange bracket is now set and ready for work.

Operation

Change of rail spacing is made by simply pushing on the composite knob, placing the desired spacer on the shaft, and releasing the knob to lock the spacer in place.

Spacers

Spacers are made in white UHMW specifically for each application. Fenner Drives Engineering department handles all the calculations required to determine spacer dimensions based on your bottle and conveyor dimensions. Standard white UHMW spacers are stocked in 1/8" increments from 1/4" up to 1 1/2" with corresponding sizes for corners. Special sizes are made as required with minimal lead times. Special colored spacers are available upon request.

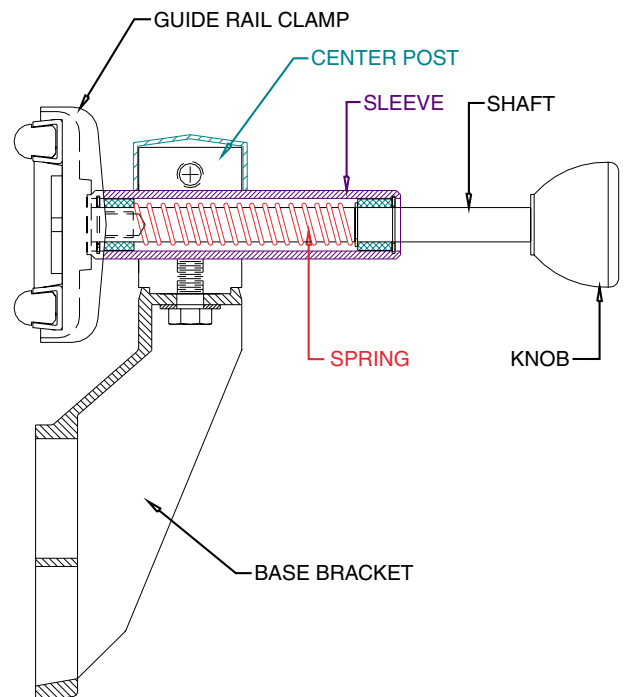

QCI...

The Original

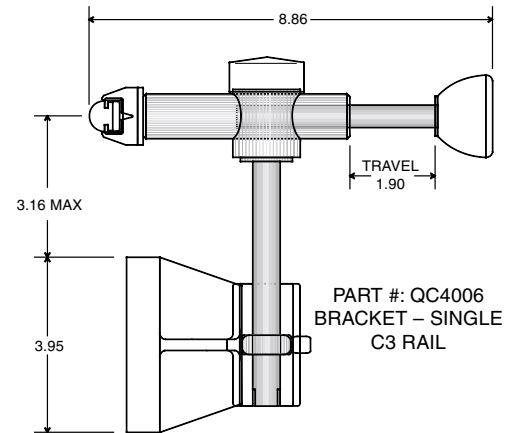
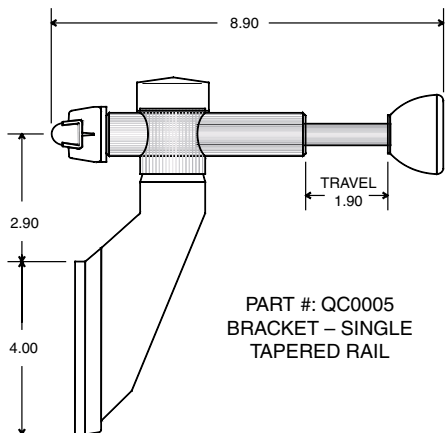
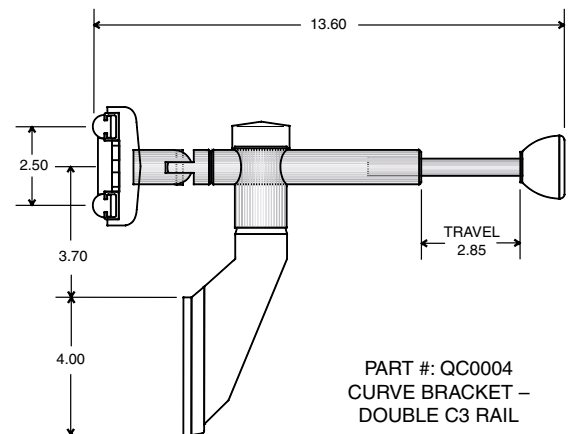
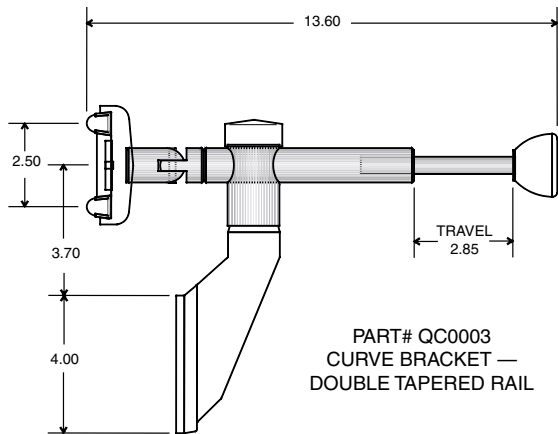
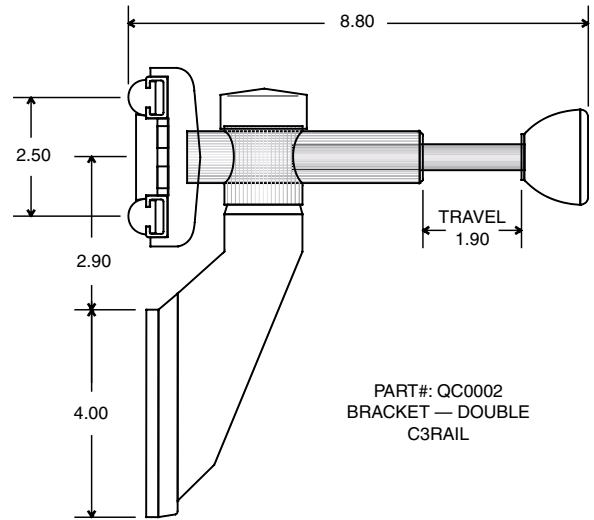
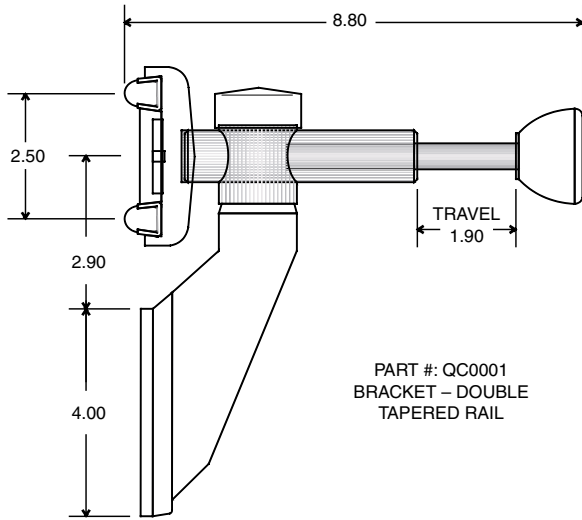

TRACKSTAR QUICKCHANGE® Brackets

QCII ...

1/8" Incremental Adjustment

Construction

The QCII has the same base bracket as QCI. The center post, cap, spring, and shaft are all precision machined from stainless steel.

Set-Up

The initial set up is even easier than with QCI. Mount your bracket to your conveyor frame with MB1005 bracket spacers, if necessary. Push down on the cap and push or pull the knob to set the guide rail position to the bottle size to be run on machine. Your new QCII bracket is now set and ready for work.

Operation

Changing rail spacing is done by pushing down on the stainless steel cap and, at the same time, pushing or pulling the plastic adjustment knob to the new position. Release the cap at the desired position and your QCII bracket is set again.

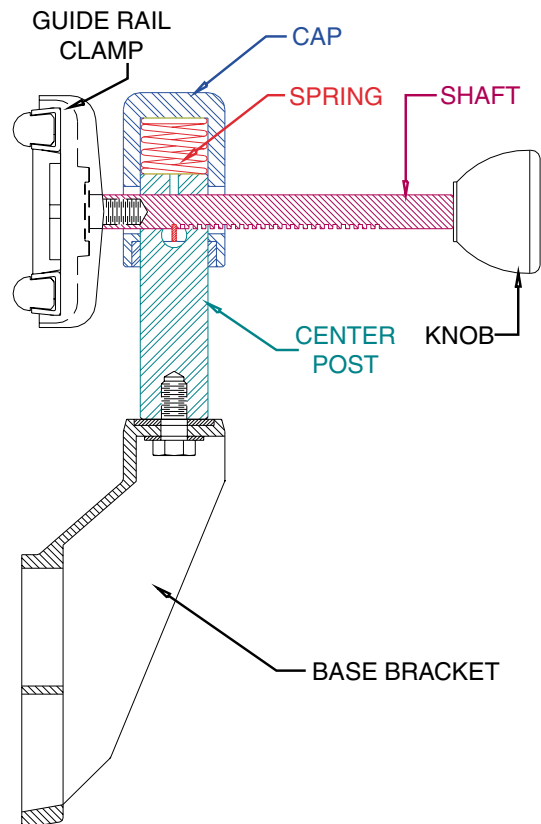

QCII...

1/8" Incremental Adjustment

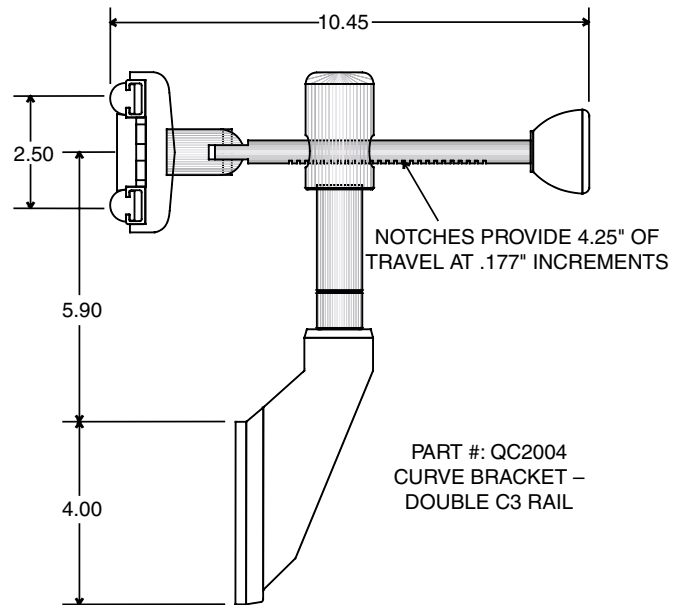
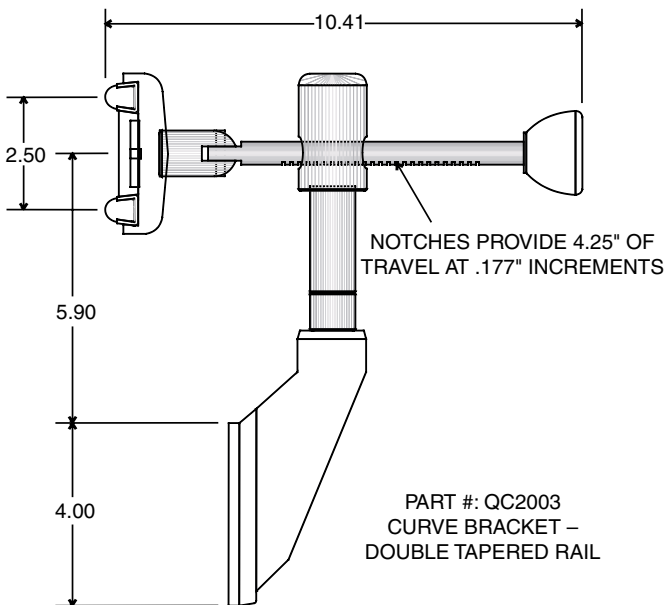
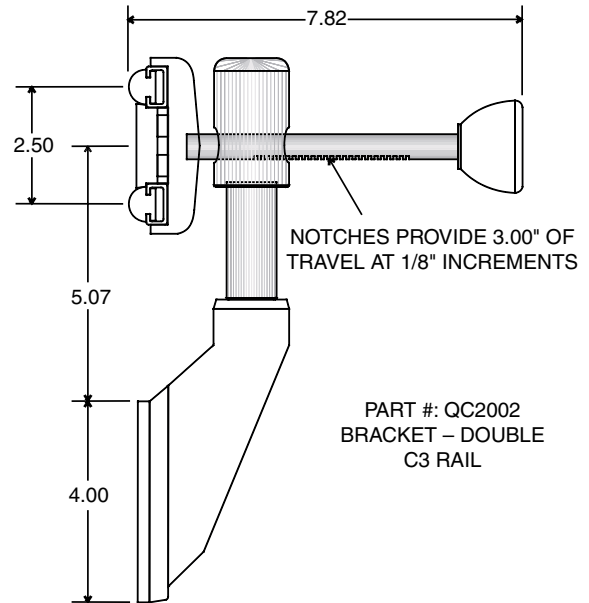
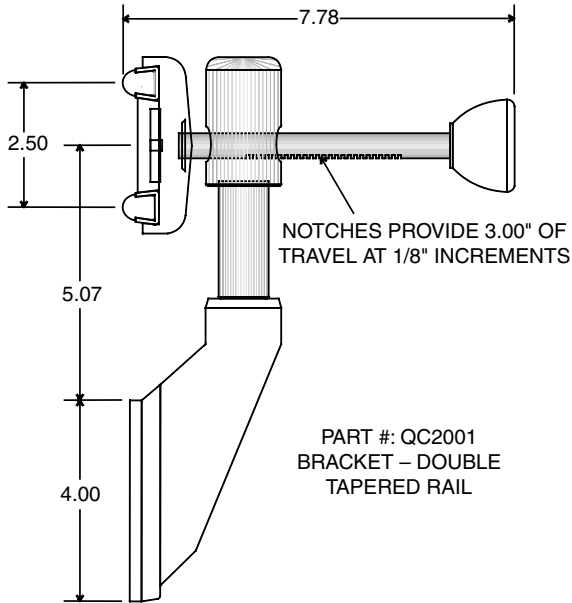

TRACKSTAR QUICKCHANGE® Brackets

QCIII ...

“The Dial”

Construction

QCIII utilizes the same rugged construction as the original QCI with the addition of a stainless steel “dial spacer.”

Set-Up

As with the QCI bracket, set-up is a one-time event. Mount the bracket to the conveyor frame with the MB1005 bracket spacers, if necessary. Set the “dial spacer” so the bracket is in its most retracted state. Using the stainless steel adjustment bolt, move the bracket sleeve to accommodate your largest bottle size. You are now set for operation.

Operation

With Fenner Drives’ unique patented dial spacers, adjustments are quick, simple, and repeatable. To make rail adjustments, simply push on the plastic knob, turn the dial to the desired position for the new bottle size, and release. It’s that simple.

The Dial Spacer

Custom made for each application, the “Fenner Dial” is precision machined from stainless steel. Our Engineering group will custom design a dial spacer for your needs, and the product can be shipped within two weeks of your request.

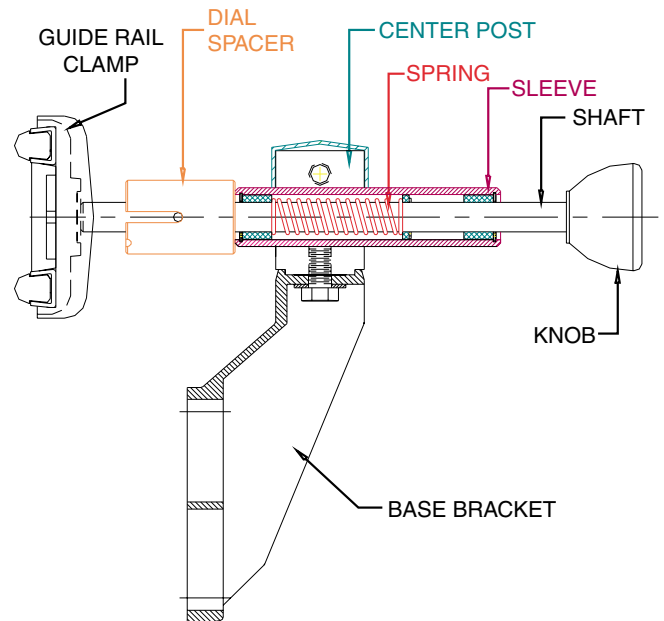

QCIII...

“The Dial”

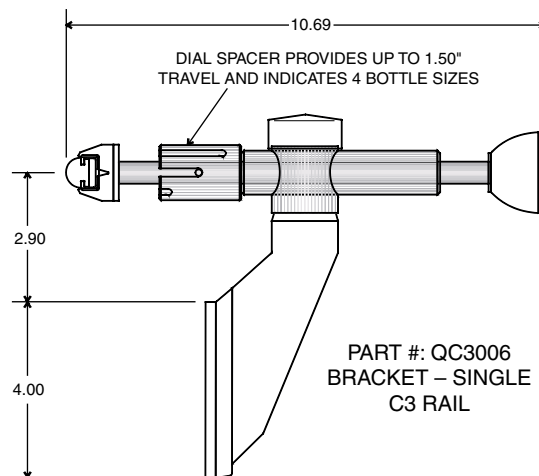
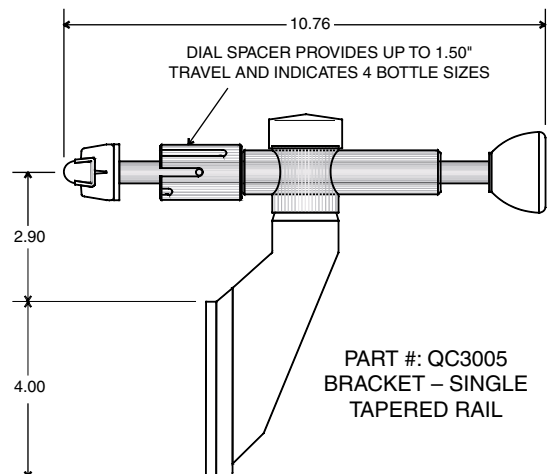
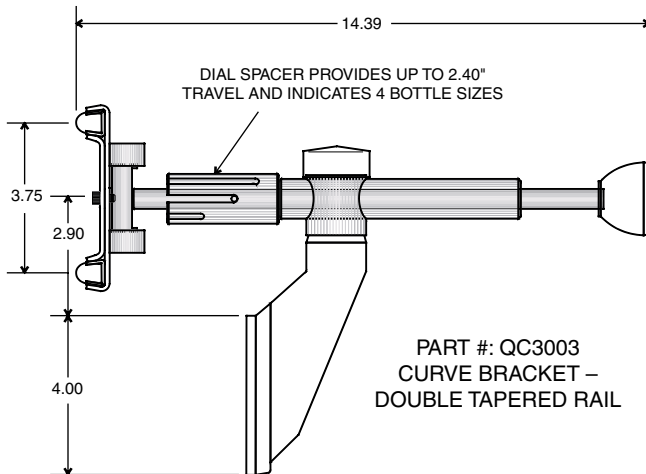
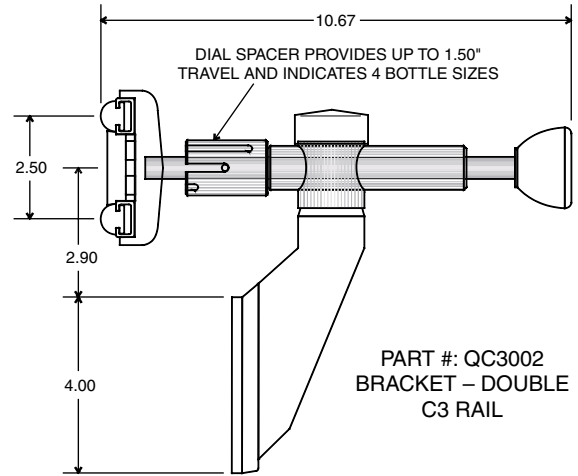
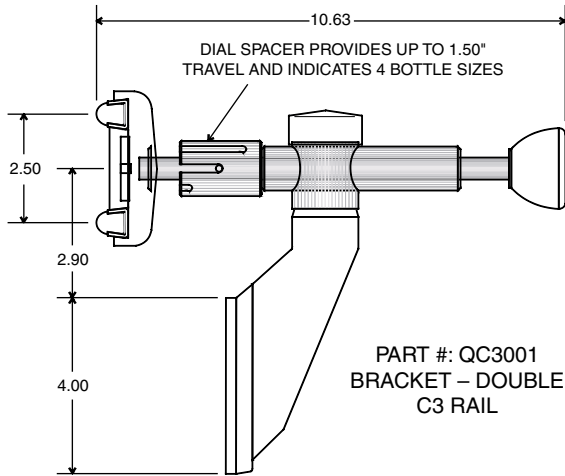

TRACKSTAR QUICKCHANGE® Brackets

QCIV ...

Vertical

Construction

Our vertical QuickChange utilizes a special base bracket molded of high-strength glass-reinforced nylon. All metal materials are stainless steel for corrosion resistance. The horizontal adjustment mechanism is made from the same materials as all of our quality QuickChange Brackets.

Set-Up

Like all of the other QuickChange brackets, the vertical QuickChange is easy to set up. Simply mount the bracket to the conveyor, adjust horizontal sleeve with set screw for the largest bottle size (see QCI) and then set height by using the vertical adjustment knob on the side of the bracket.

Operation

Horizontal spacing is made by the use of composite spacers, just like our standard QCI. Vertical adjustment is made by loosening the adjustment knob and pulling the top bracket up or letting the bracket fall to the desired height. Vertical spacers can be supplied, if required, for height adjustment.

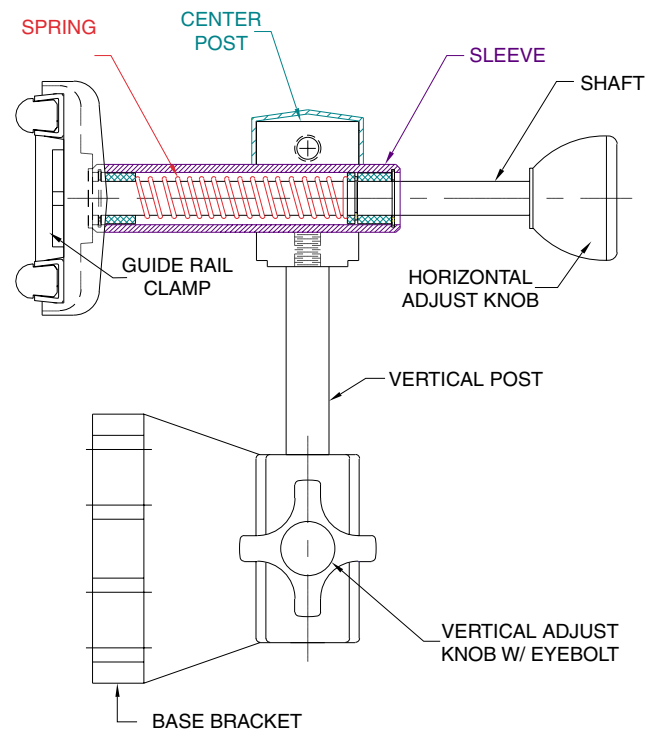

QCIV...

Vertical

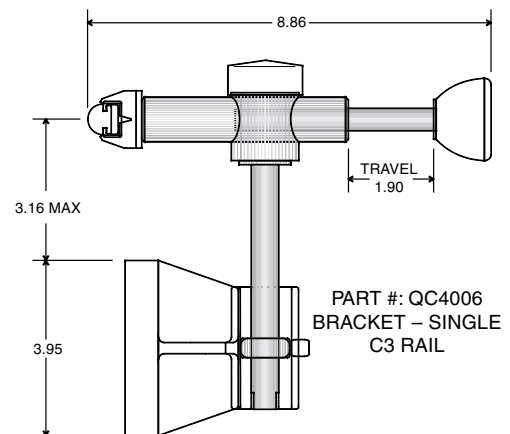
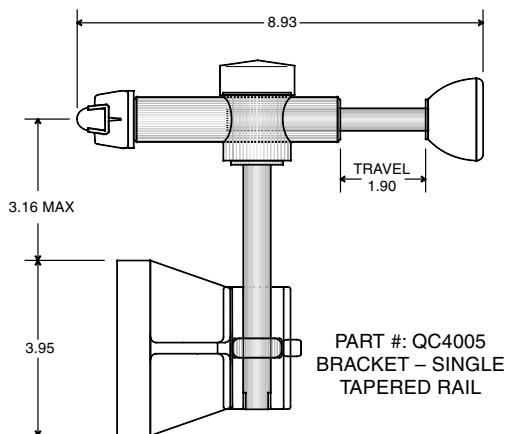
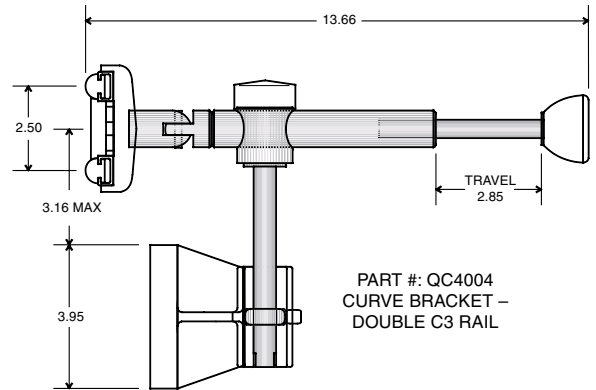
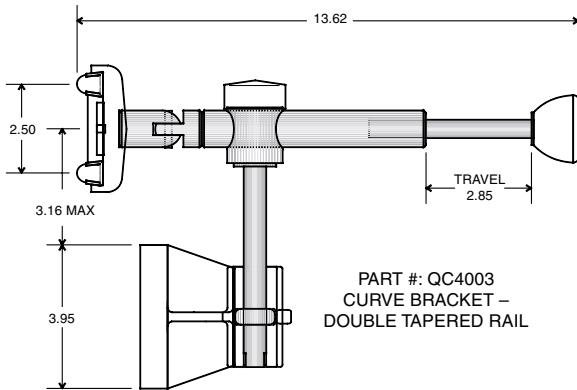
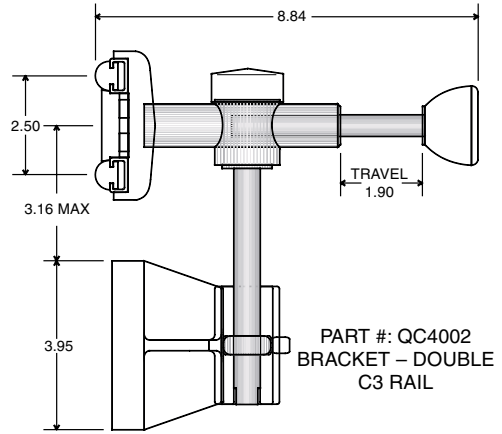
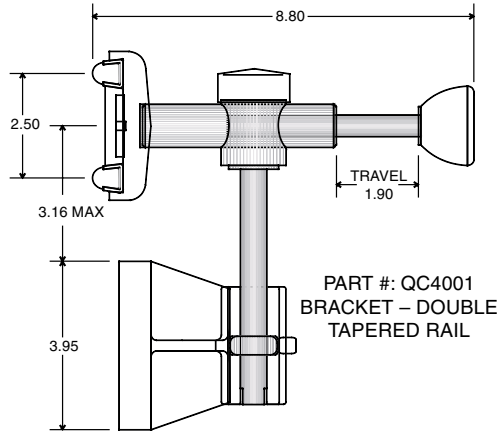

QuickChange Guide Rail Systems

The availability of both conventional tapered and high-strength C-3 guides is another QuickChange exclusive. Both tapered and C-3 guides are precision-extruded using the highest quality virgin Ultra-High-Molecular-Weight polyethylene (UHMW) to assure minimum friction and maximize abrasion resistance.

About UHMW-PE

UHMW is produced by a unique, low-temperature polymerization process, yielding an average molecular weight ten or more times that of conventional high density polyethylene resins (approximately 3 to 6 million by ASTM Test D4020). As the molecular weight of polyethylene increases, significantly high values are obtained for a number of technically important properties including impact strength, abrasion resistance, energy absorption and resistance to cracking.

C-3 Guide Rails

Fenner Drives' "C" channel design features a unique two-piece construction to facilitate quick and easy replacement of UHMW inserts, while allowing for thermal expansion. Our high-strength "C" channel rails are also stiffer by design, reducing the number of support brackets required. C-3 guide rails are available in crowned and flat profiles in F.D.A. and U.S.D.A. approved white with a corrosion-resistant #304 stainless steel channel.

Tapered Guide Rails

Fenner Drives also offers industry standard tapered guide rails for easy retro-fit on existing systems in both flat and round versions.

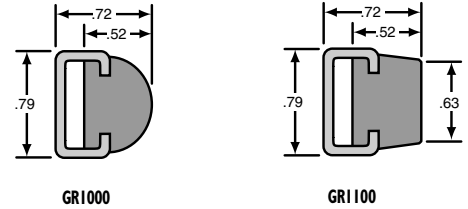

Profile	Color	Efson P/N Stainless Steel Channel
Crowned	Black	GR1000-3S120.00
Crowned	White	GR1001-3S120.00
Flat	Black	GR1100-3S120.00
Flat	White	GR1101-3S120.00

Efson P/N Aluminum Channel	Efson P/N Galvanized Channel
GR1000-3A120.00	GR1000-3G120.00
GR1001-3A120.00	GR1001-3G120.00
GR1100-3A120.00	GR1100-3G120.00
GR1101-3A120.00	GR1101-3G120.00

All Trackstar Guides are supplied in 120" standard lengths.

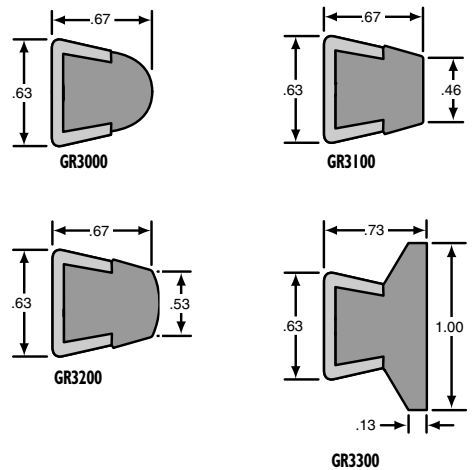

Profile	Color	Efson P/N Stainless Steel Channel	Efson P/N Galvanized Channel
Crowned	White	GR3000-S120.00	GR3000-G120.00
Flat	White	GR3100-S120.00	GR3100-G120.00
Modified Flat	White	GR3200-S120.00	GR3200-G120.00
Wide Flat	White	GR3300-S120.00	GR3300-G120.00

Rail Clamps

Trackstar Rail Clamps simplify guide rail installation and allow for easy adjustment. Single and double rails are available in both “C” channel and tapered channel designs. Specify part number BC0002 for 1/2" stainless steel rods. Single rail clamps utilize stainless steel backing plates for added rigidity. All Trackstar Clamps are easily mounted with support rods shown below.

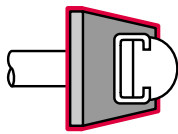

MC0001-Clamp
MC0002-Backing Plate

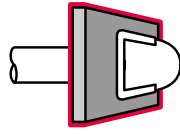

MC0006-Clamp
MC0002-Backing Plate

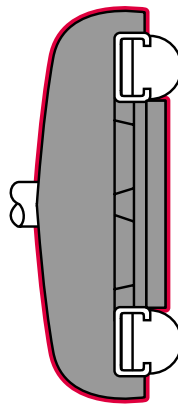

BC0001

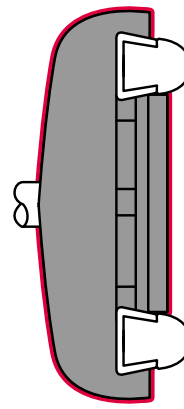

BC0006

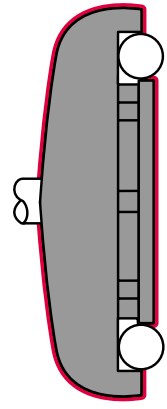

BC0002

Rail Splices

Joining rail ends together is easy with Trackstar Rail Splices. Available for both “C” (MC0003) and tapered rails (MC0007) in corrosion-resistant stainless steel. These tight fitting splices can be easily tapped on with a hammer — no screws or bolts are needed.

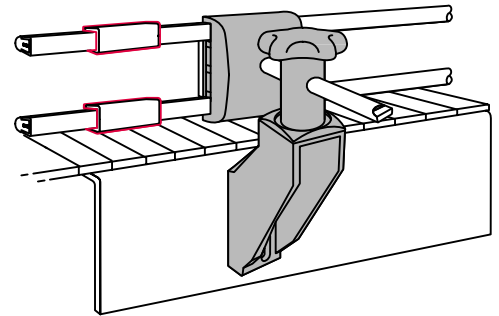

Telescoping Splices

Trackstar “C” channels’ unique two-piece construction makes connecting guide rail sections quick and easy. By simply “telescoping” the plastic rail several inches into the mating metal channel, a streamline joint is achieved with no additional parts or cost.

